

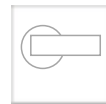

# NOVA Sawing



Ripping  
Sizing & Cutting



Scoring



Hogging

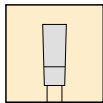

## DFH - Hoggers Saw Blades, Extended Life

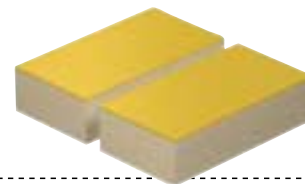
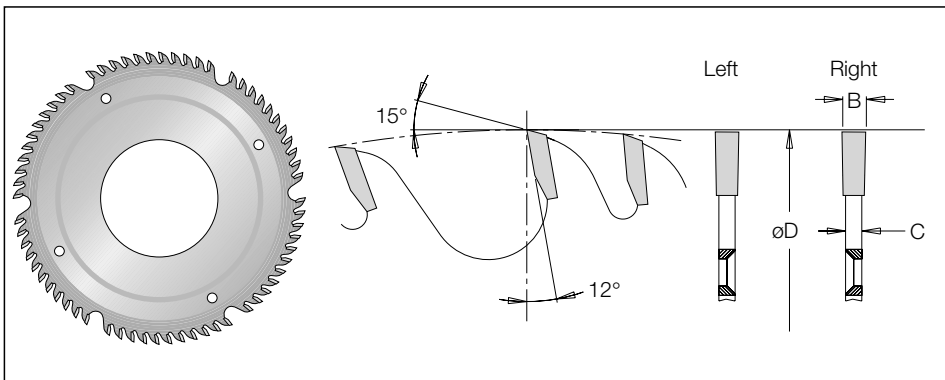

Boards, Laminated,  
Veneered boards



Across  
& Along

øD	Teeth	Code No.		B	c	ød	PH
		Right	Left				
180	54	957 01 00 S*	957 01 05 S*	3.2	2.2	65	6 / 6.5 / 90
	54	957 01 03 N*		3.2	2.2	50	3 / 22 / 80
200	40	957 01 10 U	957 01 15 U	4.0	2.8	80	4 / 6.5 / 140
	60	957 01 20 U	957 01 25 U	4.0	2.8	80	4 / 6.5 / 140
	60	957 01 21 U	957 01 26 U	4.0	2.8	80	8 / 6.5 / 155
	48	957 01 30 U	957 01 35 U	4.0	2.8	80	6 / 6.5 / 200
250	48	957 01 30 Z	957 01 35 Z	4.0	2.8	100	6 / 6.5 / 200
	72	957 01 40 U	957 01 45 U	4.0	2.8	80	6 / 6.5 / 200
	72	957 01 40 Z	957 01 45 Z	4.0	2.8	100	6 / 6.5 / 200

⚠ \* Scoring for hogging.

Manufacturing Technology:



Balance



Straight



Tension

## Segment for Hogger

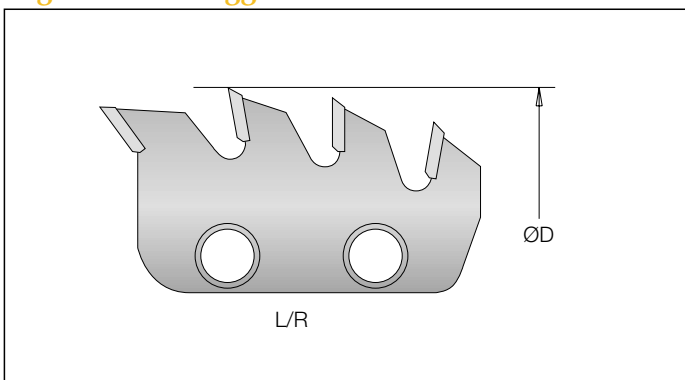

Teeth	Code No.	L/R	Suitable to segmented hogger diameter 200/250mm.
4	911 08 10 4	L/R	