

Ripping
Sizing & Cutting

Scoring

Hogging

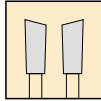

DWT - Main Saw for Panel Sizing Boards Extended Life

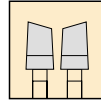
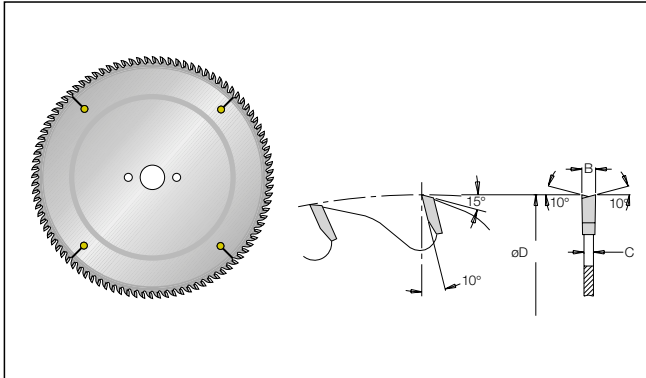

DVK - Scoring Extended Life

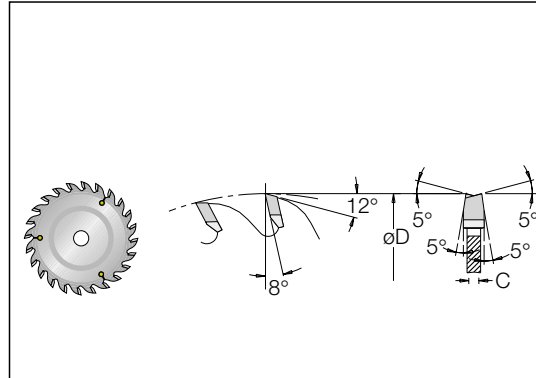

Type	øD	Teeth	Code No.	B/C	ød	NI
Mayer/	305	48	955 110 06	4.4/3.0	30	
	305	60	955 110 56	4.4/3.0	30	
	355	54	955 111 06	4.4/3.0	30	
	355	72	955 111 56	4.4/3.0	30	
Giben	355	54	955 111 0T	4.4/3.0	75	
	355	72	955 111 5T	4.4/3.0	75	
	400	72	955 113 0T	4.4/3.2	75	4/15/105
	430	54	955 114 5T	4.4/3.2	75	4/15/105
	430	72	955 115 0T	4.4/3.2	75	4/15/105
	500	72	955 119 0T	4.4/3.2	75	
Scm/	400	72	955 113 0U	4.4/3.2	80	4/9/100
Gabbiani						2/14/110
						2/7/110
Holzma	400	72	955 113 OR	4.4/3.2	60	
	420	72	955 114 OR	4.8/3.5	60	
	450	72	955 117 OR	4.8/3.5	60	2/14/125
Schelling	400	60	955 112 56	4.4/3.2	30	
Anton	400	72	955 113 OR	4.4/3.2	60	
Teutomatik	500	60	955 118 0U	4.4/3.2	80	4.4/3.2

øD	Teeth	Code No.	B/C	ød	NI
125	24	95600793	4.4/3.2	20	
125	24	95600793	4.4/3.2	20	
125	24	95600793	4.4/3.2	20	
125	24	95600793	4.4/3.2	20	
125	24	9560079M	4.4/3.2	45	
125	24	9560079M	4.4/3.2	45	
160	36	9560195M	4.4/3.2	45	
216	42	9560270N	4.4/3.2	50	3/15/80
216	42	9560270N	4.4/3.2	50	3/15/80
125	24	9560079M	4.4/3.2	45	
160	36	9560195C	4.4/3.2	55	3/7/66
150	24	95600883	4.4/3.2	20	
180	30	95602103	4.4/3.2	20	

Manufacturing Technology:



Dynamic
Balancing

Dynamic
Straightness

Tension