

Ripping  
Sizing & Cutting

Scoring

Hogging

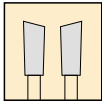

## MW - Trimming & Cross Cut Saw Blade

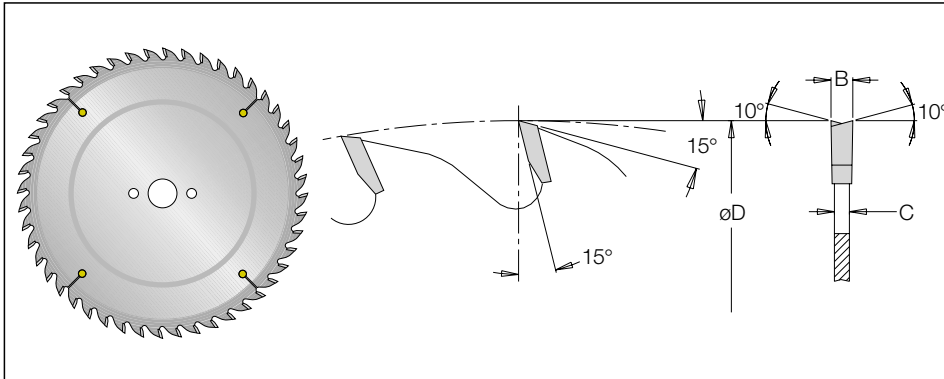

Boards



Across  
& Along

øD	Teeth	Code No.	B	c	ød
150	24	901 02 20 6	3.0	2.0	30
180	30	901 02 30 6	3.0	2.0	30
200	34	901 02 40 6	3.0	2.0	30
220	34	901 02 43 6	3.0	2.0	30
250	40	901 02 60 6	3.2	2.2	30
	48	901 02 63 6	3.2	2.2	30
300	48	901 02 70 6	3.2	2.2	30
350	54	901 02 80 6	3.5	2.5	30
400	60	901 02 90 6	3.5	2.5	30
450	66	901 03 00 6	4.0	2.8	30
500	72	901 03 20 6	4.4	3.0	30

Manufacturing Technology:



Balance



Straight



Tension



# NOVA Sawing

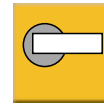

Ripping  
Sizing & Cutting

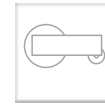

Scoring



Hogging

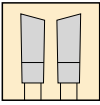

## MWD - Trimming & Cross Cut Thin Kerf Saw Blade

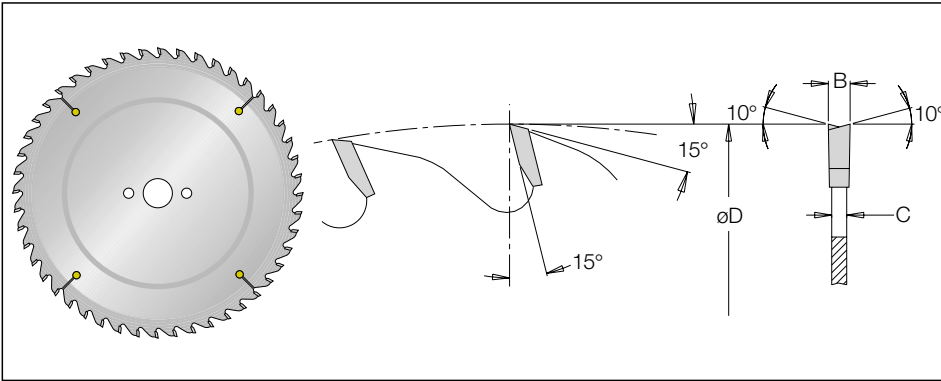

Boards



Across  
& Along

øD	Teeth	Code No.	B	c	ød
150	24	901 30 10 6	2.3	1.6	30
180	30	901 30 20 6	2.3	1.6	30
200	34	901 30 30 6	2.3	1.6	30
230	34	901 30 40 6	2.3	1.6	30
250	40	901 30 50 6	2.3	1.6	30
300	48	901 30 60 6	2.3	1.6	30
350	54	901 30 70 6	2.3	1.6	30
380	48	901 30 80 6	2.7	2.0	30

 Use a flange whose diameter is half the diameter of the saw blade

Manufacturing Technology:



Balance



Straight



Tension